

AQUA ENERGY DL-160J3

AQUA ENERGY INTERNATIONAL LTD

8 St James Business Centre, Linwood Road

Paisley PA3 3AT

Scotland, UK

Tel: (+44) (0) 141 849 6888

Fax: (+44) (0) 141 848 5777

E-mail: info@aquaenergy.com

<http://www.aquaenergy.com>

*ULTRA HIGH PRESSURE
INDUSTRIAL PLUNGER PUMP*

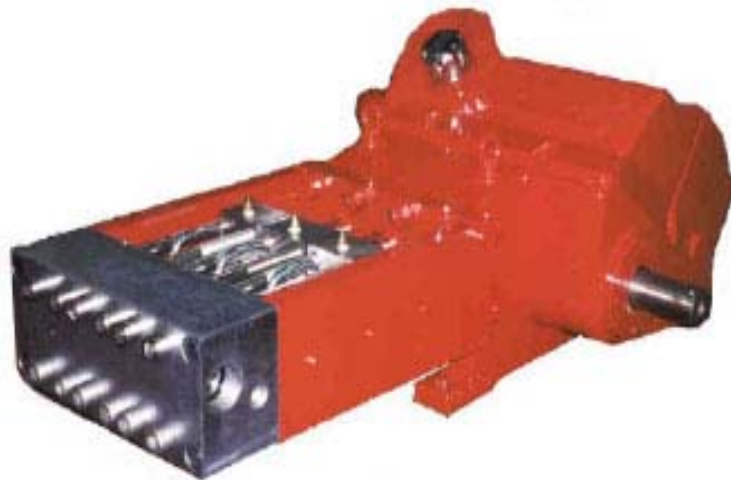

PUMP SPECIFICATIONS

Rated Horsepower -----215

Number of cylinders -----3

Plunger Stroke -----mm79

Oil Capacity -----lt 14

Plunger Load ----- 5,545Kg

Pump Weight -----Kg 386

FLUID END

FLUID HEAD - Special high resistance stainless steel.

VALVES & SEATS – Valves made in stainless steel and bronze seats.

PLUNGERS - Ceramic or Nickel-Chrome-Boron.

PACKING – Pressure Packing internal cooling system. Double pressure packings

LUBRICATION - Plungers and Packing lubricated by water supply with water spill venting.

POWER END

POWER FRAME - High strength cast iron.

CRANKSHAFT - Hardened and tempered alloy steel.

CRANKSHAFT BEARINGS - Double roller rim.

CONNECTING RODS - Surface treated spheroidal cast Iron.

REDUCTION GEAR - Internal 3.60:1 for 1800 rpm. reduction ratio gear from either side of pump.

LUBRICATION – Power end parts and gearbox are splash lubricated by oil in crankshaft reservoir.

DL-160-J3 SERIES

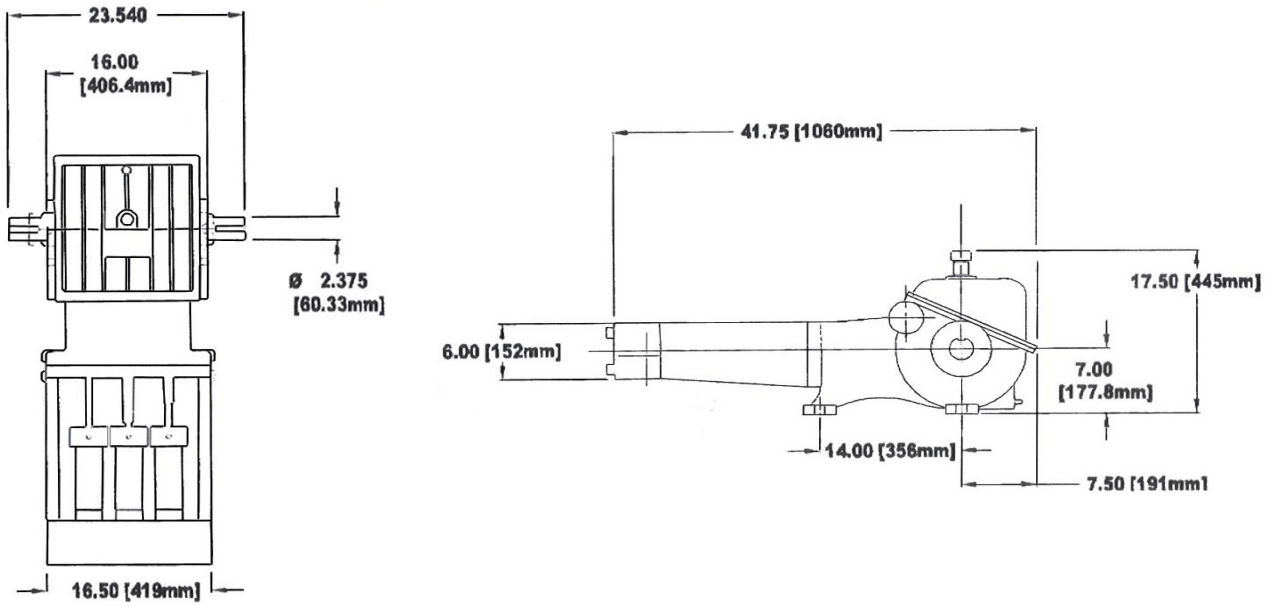

DL-160-J3 PUMP

Maximum design pressure: **2758 bar** (40,000psi)

Maximum inlet pressure: **7 bar** (101.50 psi)

Minimum inlet pressure: **3 bar** (43.50 psi)

Standard connections: Suction ----- G 1-1/2"

Discharge ----- 9/16" AE-HP

Table of pump versions

CAPACITY IN GPM & LPM - 100% VOLUMETRIC EFFICIENCY				
40k UHP - CYLINDERS				
PUMP SPEED	40,000 PSI	2758 BAR	30,000 PSI	2034 BAR
RPM	GPM	L-Min	GPM	L-MIN
100	1.20	04.56	1.50	05.70
200	2.40	09.12	3.00	11.40
300	3.60	13.68	4.50	17.10
400	4.80	18.24	6.00	22.80
450	5.40	20.52	6.70	25.46
500	6.80	25.84	7.50	28.50

The liquid-ends of the **160J3** pump offer many ease of maintenance features. The segmented liquid cylinders are held to a common manifold by four through manifold bolts that screw into a back cylinder holding plate. The removal of each cylinder is a simple task which requires only the unscrewing of the plunger from the pony rod and the removal of the four through-manifold bolts, which are accessible from the front side of the manifold. Packing, plunger, valves and cylinder changes can be accomplished in short time spans and do not require special skills of the workman. In fact, the valve cartridge can be removed from the pump without loosening the plunger or disturbing the packing. All that is required is to loosen the four through-manifold bolts and then slide the back of the cylinder approximately two inches toward the power-end. The valve cartridge can then be easily lifted from between the manifold and cylinder. This feature is great for quick suction and discharge valve inspection or component changing. When it comes to ease of field maintenance, no other through-bore type pump comes close to the exceptional versatility of the **160J3** pump.

AQUA ENERGY